

# PRODUKTOVERSIKT

## Icopal Brettex



undertak/vindsperre



Nr. 1024-300  
Dato: 01.04.2006

Produkt	Nobb nr.	Dimensjon	Vekt pr. plate/pk.	Antall pr. pall	Ca. vekt pr. pall		
<b>Icopal Brettex</b> Kombinert undertak/vindsperre. Diffusjonsåpent	10207785	1,30m x 5,40m =7,02m <sup>2</sup>	10 kg	64 pk. =449,28m <sup>2</sup>	665 kg		
	10499259	1,30m x 6,48m =8,42m <sup>2</sup>	12 kg	52 pk. =438,00m <sup>2</sup>	628 kg		
	10207777	1,30m x 7,02m =9,12m <sup>2</sup>	13 kg	48 pk. =437,76m <sup>2</sup>	650 kg		
	10207769	1,30m x 9,18m =11,93m <sup>2</sup>	17 kg	36 pk. =429,48m <sup>2</sup>	637 kg		
		Nettomål: 1,20m x lengde* Pakkeformat: 1,30m x 0,27m					

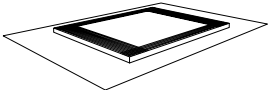
### Tilbehørsprodukter

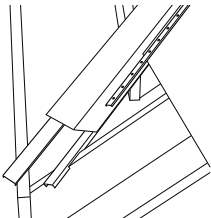
Produkt	Nobb nr.	Dimensjon	Enhet	Innhold pr. enhet	
<b>Icopal Gjennomføringsmansjett</b> For gjennomføringer i forenklede undertak		23100183	Yttermål flens 700 x 1075 mm  Åpning 500 x 700 mm	stk.	1
<b>Icopal Klemlist</b> m/skruer		23100175	Lengde/bredde 530/39,5 mm	pk.	10 stk. (inkl. skruer)
<b>Underbeslagsystem kilrenne</b> Pakken består av: underbeslag 2m, 2 stk stål kubbelist á 2m med 8 stk knappeskruer 8 klemmlister á 0,53m, 32 stk skruer		30150346	2 m	pk.	1 sett
<b>Universal Skjøtebånd</b>	21747357 21747340	1 x 30 mm	10 m 20 m		1 rull pr. pk.

TopSafe/Super D til kilrenne, se egen liste.



06050-P

Icopal as  
Postboks 55  
1477 Fjellhamar  
Tlf. 67 97 90 00  
Fax 67 90 58 77  
www.icopal.no